

# **GO** REGULATOR, INC.

A division of CIRCOR International, Inc.



## **SBPR Series Subatmospheric Back Pressure Regulator**

The SBPR Series subatmospheric back pressure regulator is designed to provide precise upstream vacuum control. One example of this could be to introduce a sample gas at a positive pressure into a vacuum chamber. Downstream of this chamber would be the SBPR and a vacuum pump. The positive pressure will build up in the chamber causing the SBPR to open and allow the chamber to return to the vacuum desired. The SBPR will then close and the process will repeat. The large diameter diaphragm aided by a vacuum assist spring, provides the user with optimum sensitivity for subatmospheric pressure control.

### **Features & Specifications**

- Subatmospheric or positive back pressure control
- Stainless steel or brass construction
- Large diaphragm for sensitive pressure control
- Adjustable pressure control range 1-30 psia (-27.7in. H<sub>2</sub>O to 15.3 psig)
- C<sub>v</sub> flow coefficient 0.2
- Operating temperatures -40° F (-40° C) to +300° F (+148° C)
- Inlet / outlet connections 1/4" FNPT

### **Options**

- Extra ports
- Panel mount (requires a 1 3/8" mounting hole)
- Pressure gauges
- Optional welded connections
- Smaller orifice size available—0.03
- Monel and Hastelloy

2301 Wardlow Circle  
Corona, CA 92880  
tel 909.270.6200  
fax 909.270.6201  
www.goreg.com  
sales@goreg.com

# SBPR Series

## Subatmospheric Back Pressure Regulator

### How to Order

See page 3 for standard configurations. For additional configurations, consult the factory.  
See page 4 for port locations.

### Maximum Temperature & Control Pressures

Seat Material	Maximum Temperature*	@	Maximum Control Range
Viton®	250° F (121° C)	@	1 - 30 psia
Kalrez®	300° F (148° C)	@	1 - 30 psia
Teflon®	200° F (93° C)	@	1 - 30 psia

\* Temperatures in excess of 175° F (80° C) require the use of a T-handle or the tamper proof option.  
Viton®, Kalrez® and Teflon® are registered trademarks of Dupont.

### Outline and Mounting Dimensions

Weight - 3.2 lbs (1.45 kg)

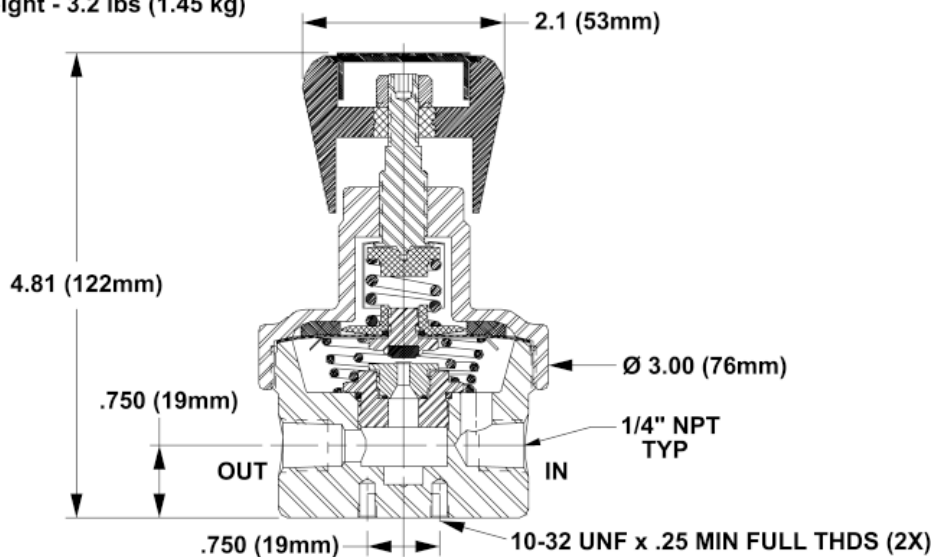

# SBPR Series - Back Pressure Regulator (US Dollars)

<b>Material of Body</b>	
1	SS 316L
2	Brass
4	Monel
6	Hastelloy C
<b>Port Configuration (page 28)</b> STANDARD BODY "A" (ONE INLET PORT AND ONE OUTLET PORT)	
A	
<b>Process port types (gauge port type, if specified)</b>	
1	1/4" FNPT (1/4" FNPT Gauge Ports)
2	1/4" Tube (1/4" Tube Gauge Ports)
4	3/8" FNPT (1/4" FNPT Gauge Ports)
5	1/2" FNPT (1/4" FNPT Gauge Ports)
<b>Surface Finish of Diaphragm Cavity</b>	
1	<25 Ra
<b>Actuator Material</b>	
D	Viton
I	Teflon
K	Kalrez
<b>Flow Coefficient (Cv)</b>	
1	0.03
5	0.2
<b>Control Range</b>	
A	1 - 30 Psia
<b>Diaphragm Type</b>	
1	Standard
<b>Diaphragm Facing / Backing Material</b>	
1	Teflon / SS
2	Teflon / Viton
8	Teflon / Inconel
0	Teflon / Hastelloy C
<b>Cap Assembly</b>	
1	Standard, S.S.
2	T-Handle, S.S.
3	T-Handle, Panel Mount, S.S.
4	Panel Mount, S.S.
5	Captured Vent, Aluminum
6	Captured Vent, Panel Mount, Aluminum
7	Captured Vent, S.S.
8	Tamper Proof, S.S.
9	Fine Adjust, 1/2" Panel Mount, S.S.
0	Fine Adjust, 1 3/8" Panel Mount, S.S.
C	Captured Vent, Panel Mount, S.S.
E	Tamper Proof, Panel Mount, S.S.
H	1/4" NPT Dome Loaded, S.S.



# PORT LOCATIONS (BACK PRESSURE REGULATORS)

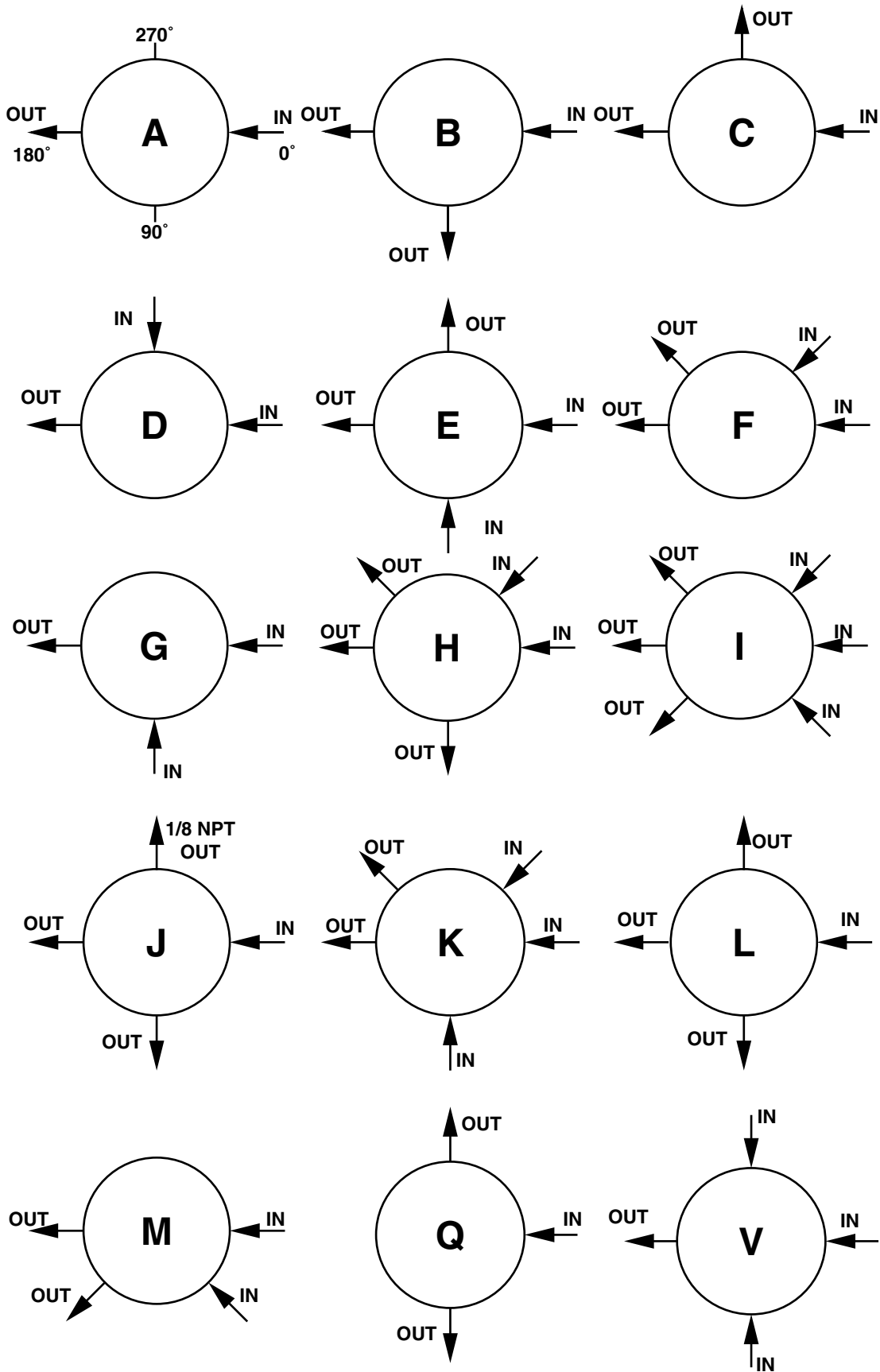

LOCATION OF PORTS FROM TOP VIEW