



**GO** REGULATOR, INC.  
A division of CIRCOR International, Inc.

## **CYL-2 Series**

### **Two-Stage Brass Cylinder Gas Pressure Reducing Regulator**

The CYL-2 Series is a precision two-stage regulator well suited for instrumentation applications requiring a precise and stable pressure source. This pressure regulator was developed to meet the needs of the instrumentation industry, but is also well suited for other applications requiring precision pressure supply.

The development of this series provides the maximum flexibility that is available in any cylinder regulator. This means that you can select optional diaphragm materials for maximum sensitivity with Teflon® lined stainless steel being standard.

### **Features & Specifications**

- Brass construction
- 1<sup>st</sup> stage integral 20 micron filter and 2<sup>nd</sup> stage 40 micron integral filter
- Teflon® lined stainless steel diaphragm in both stages
- Tefzel® seats are standard
- 2" diameter brass gauges
- CGA inlet fitting
- Optional relief valves and shut off valves
- Maximum inlet pressure 3600 psig
- Outlet pressure ranges 0–10, 0–25, 0–50, 0–100, 0–250 and 0–500 psig
- Fluid media; non-corrosive gases
- C<sub>v</sub> flow coefficients 0.06, 0.025, 0.20, 0.50
- Operating temperatures -40° F (-40° C) to +175° F (+80° C)
- 1/4" FNPT inlet/outlet connections

2301 Wardlow Circle  
Corona, CA 92880  
tel 909.270.6200  
fax 909.270.6201  
[www.goreg.com](http://www.goreg.com)  
[sales@goreg.com](mailto:sales@goreg.com)

# CYL-2 Series

## Two-Stage Brass Cylinder Gas Pressure Reducing Regulator

### How to Order

See page 3 for standard configurations. For additional configurations, consult the factory.  
See page 4 for port locations.

### Maximum Temperature & Operating Inlet Pressures

Seat Material	Maximum Temperature	@	Maximum Operating Inlet Pressure
Tefzel®	150° F (66° C)	@	3600 psig (24.82 MPa)
High Density Teflon®	150° F (66° C)	@	3600 psig (24.82 MPa)
PCTFE (Formerly Kel-F-81)	175° F (80° C)	@	3600 psig (24.82 MPa)
Polyimide	175° F (80° C)	@	3600 psig (24.82 MPa)
PEEK	175° F (80° C)	@	3600 psig (24.82 MPa)

Tefzel® and Teflon® are registered trademarks of Dupont.

### Outline and Mounting Dimensions

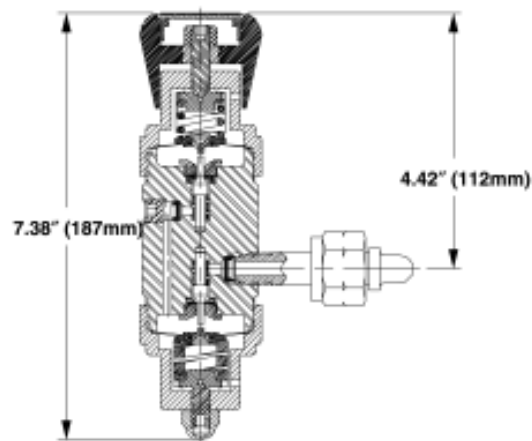
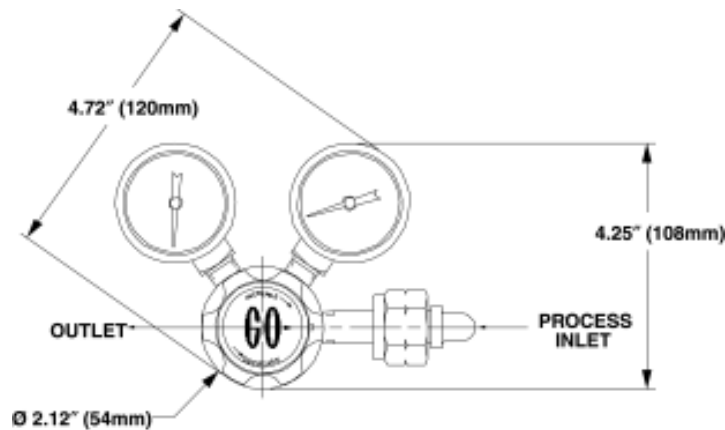

Weight - 3.5 lbs (1.59 kg)

For flow curve charts, go to [www.goreg.com/catalog/pr/cyl/cyl2/cyl2\\_flow.htm](http://www.goreg.com/catalog/pr/cyl/cyl2/cyl2_flow.htm).



# PORT LOCATIONS (CYLINDER REGULATORS)

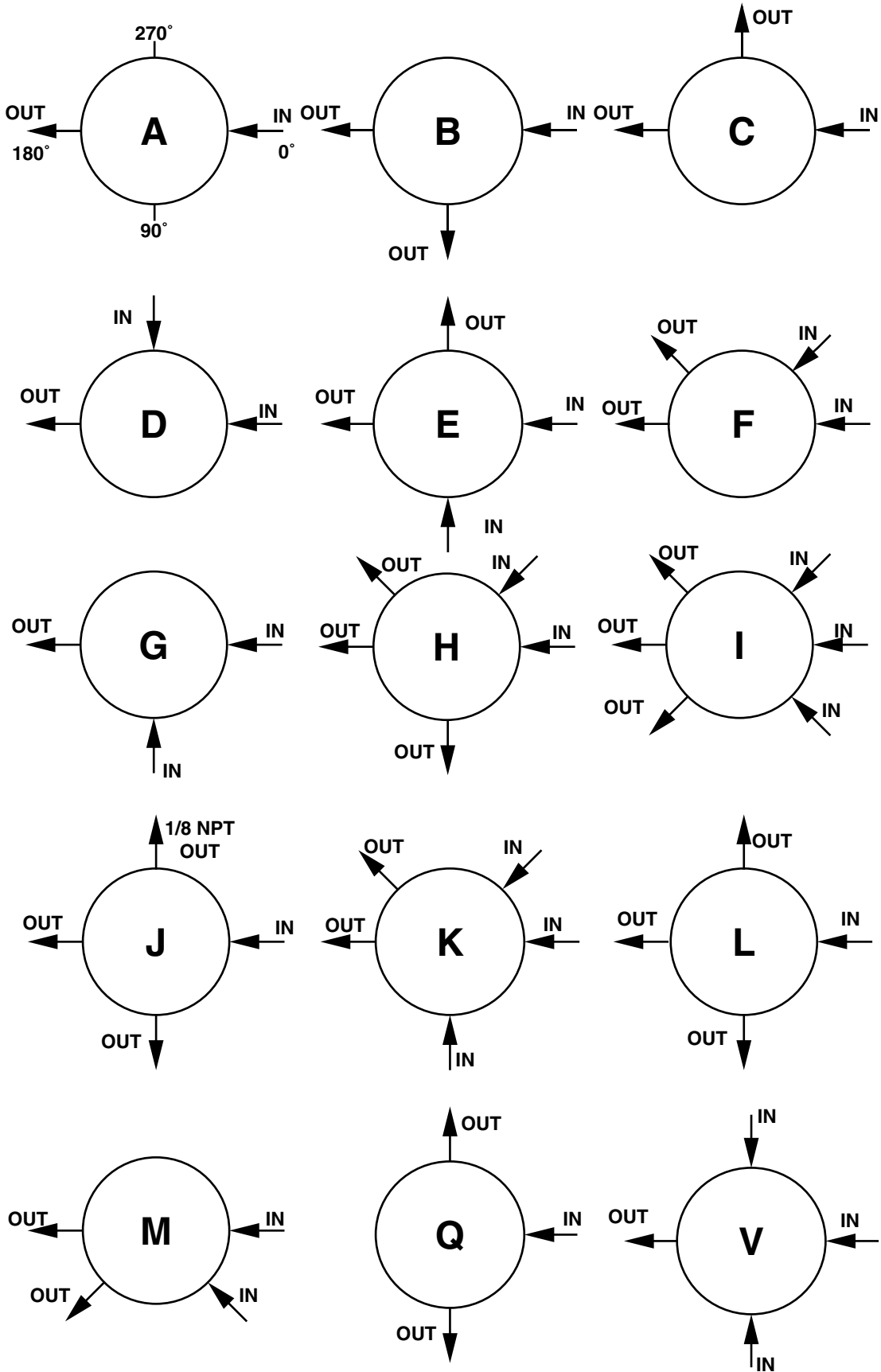

LOCATION OF PORTS FROM TOP VIEW