



Ultramite™ 70 Series

Fixed End 2- and 3-way Ball Valves

Ultramite™ 70 Series valves are designed to guard against accidental disassembly. The tamper-proof fixed end fittings are welded in place, with the exception of the 7065 Series which are pinned.



Typical Applications

- High pressure test stands
- Sampling lines
- Instrument lines
- Analyzer labs

Technical Data

| | |
|-------------------------------------|---------------------------------------|
| BODY MATERIAL* | 316 stainless steel, brass, Monel® |
| MAXIMUM OPERATING PRESSURE** | 6000 psig @ 70° F (414 bar @ 21° C) |
| OPERATING TEMPERATURE RANGE | -40° F to +350° F (-40° C to +177° C) |
| ORIFICE SIZES | 0.093 to 0.375 (2.3 to 9.5mm) |
| Cv FACTORS | 0.15 to 1.40 |

* Consult factory for other materials

** Depending on individual series.

Features & Benefits

- Fixed end fittings prevent accidental disassembly, enhancing safety.
- Floating ball provides pressure-assisted sealing and temperature wear compensation for longer valve cycle life and greater value.
- Encapsulated seats extend cycle life, reducing cost of ownership.
- Check seals improve leak tightness thereby increasing seat life.
- Oval trip-proof handle helps prevent accidental actuation. Quarter turn handle provides a visual indication of on/off valve position, improving safety.
- Special High Tolerance NPT Thread

HOKE Incorporated

405 Centura Court • PO Box 4866 (29305) • Spartanburg, SC 29303
Phone (864) 574-7966 Fax (864) 587-5608
www.hoke.com • sales@hoke.com

ball valves

Ultramite™ 70 Series

Ultramite™ 7015, 7022 Series (2-way valves)



Cv Factors: 0.23 to 1.40

Typical Applications

- High pressure test stands
- Sampling lines
- Instrument lines
- Analyzer labs

Technical Data

| | |
|---|--|
| BODY MATERIAL | 316 stainless steel, brass, Monel® |
| OPERATING PRESSURE RANGE @ 70° F (21° C) | 7015: Moderate vacuum* to 6000 psig (414 bar) 7022: Moderate vacuum* to 1500 psig (103 bar) |
| OPERATING TEMPERATURE RANGE | 7015: -40° F to +350° F (-40° C to +177° C) 7022: 0° F to +350° F (-18° C to +177° C) |
| ORIFICE SIZES | 0.093" to 0.250" (2.3 to 6.3mm) |
| Cv FACTORS | 0.23 to 1.40 |
| END CONNECTIONS | 1/8" to 3/8" Gyrolok® 1/4" NPT |

* Moderate vacuum is 10⁻³ to 20 torr.

Features & Benefits

- Fixed end fittings prevent accidental disassembly, enhancing safety.
- Oval trip-proof handle helps prevent accidental actuation. Quarter turn handle provides a visual indication of on/off valve position, providing improved safety.
- Dual encapsulated TFE seats and microfinished ball ensure a bidirectional, leak tight seal. This provides greater valve versatility and operator peace of mind.
- Floating ball provides pressure-assisted sealing and temperature wear compensation for longer valve cycle life and greater value.
- Dyna-Pak® packing provides a leak-tight seal with low operating torque in vacuum or high pressure applications, helping to eliminate fugitive emissions.
- A wide variety of Hoke Gyrolok® end fittings or pipe fittings provide the correct fitting option for the application.

Pressure vs. Temperature Curve

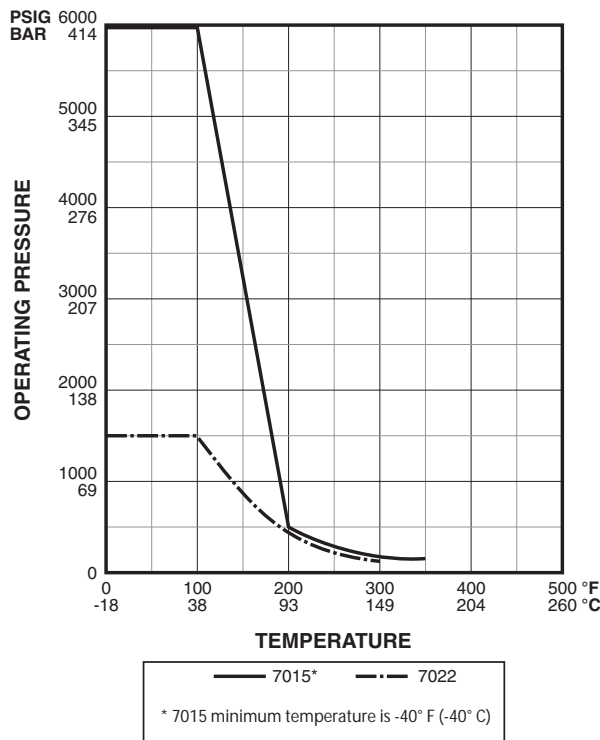

Flow Diagrams 2-way valve

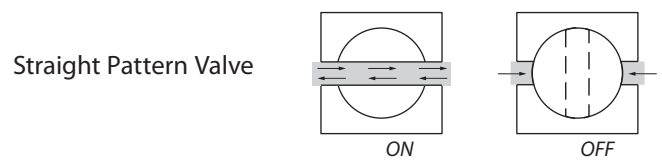

Ultramite™ 70 Series

Materials of Construction

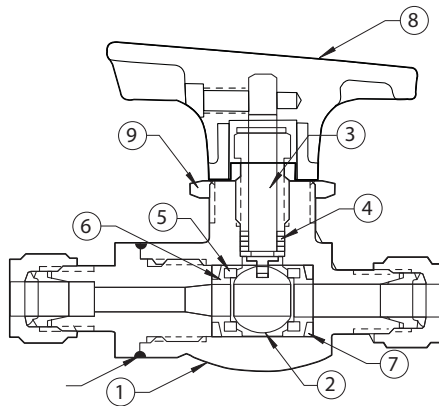

Weld

| DESCRIPTION | BRASS | 316 ST. STEEL | MONEL® |
|----------------------|--------------------------------|--------------------------------|---------------------|
| 1 Body | Brass | 316 stainless steel | Monel® |
| 2 Ball | 316 stainless steel | 316 stainless steel | Monel® |
| 3 Stem | 316 stainless steel | 316 stainless steel | Monel® |
| 4 Stem packing | TFE/316 stainless steel wafers | TFE/316 stainless steel wafers | TFE/Monel® wafers |
| 5 Seats | | | |
| 7015 Series | — | PCTFE | — |
| 7022 Series | TFE | TFE | TFE |
| 6 Seat retainers | Brass | 316 stainless steel | Monel® |
| 7 Seat washers† | | | |
| 7015 Series | — | Viton® | — |
| 7022 Series | TFE | TFE | TFE |
| 8 Handle | Nylon | Nylon | Nylon |
| 9 Panel mounting nut | Nickel-plated brass | 316 stainless steel | Nickel-plated brass |

† Other elastomers are available upon request. Contact your local distributor.

Dimensions

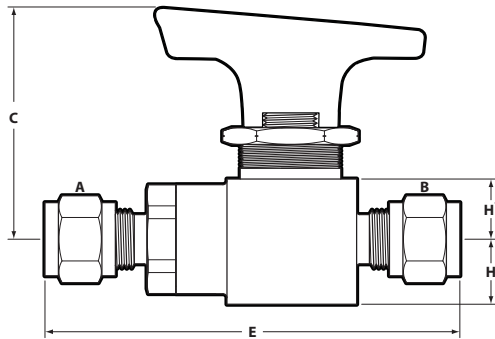

| INLET A | OUTLET B | C | E | H | H' | |
|-----------------|-----------------|------|---------|---------|--------|---------|
| 1/8" Gyrolok® | 1/8" Gyrolok® | inch | 1 13/32 | 2 19/32 | 1 3/32 | 1 11/32 |
| | | mm | 36 | 66 | 10 | 9 |
| 1/4" Gyrolok® | 1/4" Gyrolok® | inch | 1 3/4 | 3 1/16 | 1/2 | 7/16 |
| | | mm | 44 | 78 | 13 | 11 |
| 1/4" male NPT | 1/4" Gyrolok® | inch | 1 7/8 | 2 7/8 | 1/2 | 7/16 |
| | | mm | 48 | 73 | 13 | 11 |
| 1/4" male NPT | 1/4" male NPT | inch | 1 7/8 | 2 17/32 | 1/2 | 7/16 |
| | | mm | 48 | 64 | 13 | 11 |
| 1/4" male NPT | 1/4" female NPT | inch | 1 7/8 | 2 17/32 | 1/2 | 7/16 |
| | | mm | 48 | 64 | 13 | 11 |
| 1/4" female NPT | 1/4" female NPT | inch | 1 3/4 | 2 7/16 | 1/2 | 7/16 |
| | | mm | 44 | 62 | 13 | 11 |
| 3/8" Gyrolok® | 3/8" Gyrolok® | inch | 1 3/4 | 3 7/32 | 1/2 | 7/16 |
| | | mm | 44 | 82 | 13 | 11 |

Panel Mounting

Panel hole: for 1/8" Gyrolok® 1 9/32" (15mm) diameter
for all other models 4 9/64" (19mm) diameter

Panel thickness: for 1/8" Gyrolok® 3/16" (5mm) diameter
for all other models 1/4" (6mm) diameter

Dimensions for reference only, subject to change.

How to Order Standard Valves



7022F4B

Ultramite™ 7015 Series Pressure to 6000 psig (414 bar), PCTFE Seats—Viton® washers
Temperature range: -40° F to 300° F (-40° C to +149° C)

| END CONNECTIONS | | ORDER BY PART NUMBER | | ORIFICE | Cv |
|-----------------|-----------------|----------------------|--|---------|------|
| INLET | OUTLET | 316 ST. STEEL | | | |
| 1/4" Gyrolok® | 1/4" Gyrolok® | 7015G4Y | | 0.187 | 0.80 |
| 1/4" male NPT | 1/4" Gyrolok® | 7015H4Y | | 0.187 | 0.80 |
| 1/4" male NPT | 1/4" female NPT | 7015L4Y | | 0.250 | 1.40 |
| 1/4" female NPT | 1/4" female NPT | 7015F4Y | | 0.250 | 1.40 |
| 3/8" Gyrolok® | 3/8" Gyrolok® | 7015G6Y | | 0.250 | 1.40 |

Ultramite™ 7022 Series Pressure to 1500 psig (103 bar), TFE Seats—TFE Washers
Temperature range: 0° F to 350° F (-18° C to +177° C)

| END CONNECTIONS | | ORDER BY PART NUMBER | | | ORIFICE | Cv |
|-----------------|-----------------|----------------------|---------------|---------|---------|------|
| INLET | OUTLET | BRASS | 316 ST. STEEL | MONEL® | | |
| 1/8" Gyrolok® | 1/8" Gyrolok® | — | 7022G2Y | — | 0.093 | 0.23 |
| 1/4" Gyrolok® | 1/4" Gyrolok® | 7022G4B | 7022G4Y | 7022G4M | 0.187 | 0.80 |
| 1/4" male NPT | 1/4" Gyrolok® | — | 7022H4Y | — | 0.187 | 0.80 |
| 1/4" male NPT | 1/4" male NPT | — | 7022M4Y | — | 0.250 | 1.40 |
| 1/4" male NPT | 1/4" female NPT | 7022L4B | 7022L4Y | — | 0.250 | 1.40 |
| 1/4" female NPT | 1/4" female NPT | 7022F4B | 7022F4Y | 7022F4M | 0.250 | 1.40 |
| 3/8" Gyrolok® | 3/8" Gyrolok® | 7022G6B | 7022G6Y | 7022G6M | 0.250 | 1.40 |

Ultramite™ 70 Series

Ultramite™ 7092, 7093 Series (2-way Valves)



Cv Factor: 3.4

Features & Benefits

- Fixed end fittings prevent accidental disassembly, enhancing safety.
- Oval trip-proof handle helps prevent accidental actuation. Quarter turn handle provides a visual indication of on/off valve position, providing improved safety.
- Dual encapsulated TFE seats and microfinished ball ensure a leak tight seal. This provides greater valve reliability and operator peace of mind.
- Floating ball provides pressure-assisted sealing and temperature wear compensation for longer valve cycle life and greater value.

Typical Applications

- Slurry handling
- Refinery pilot plants
- Pneumatic systems
- Corrosives handling

Technical Data

| | |
|---|--|
| BODY MATERIAL | 316 stainless steel, brass, Monel® |
| OPERATING PRESSURE RANGE @ 70° F (21° C) | 7092 Series Moderate vacuum* to 2000 psig (138 bar) 7093 Series Moderate vacuum* to 5000 psig (345 bar) |
| OPERATING TEMPERATURE RANGE | -20° F to +350° F (-29° C to +177° C) (both series) |
| ORIFICE SIZE | 0.375" (9.5mm) |
| Cv FACTOR | 3.4 |
| END CONNECTIONS | ½" Gyrolok® ⅜" to ½" NPT |

* Moderate vacuum is 10⁻³ to 20 torr.

Pressure vs. Temperature Curve

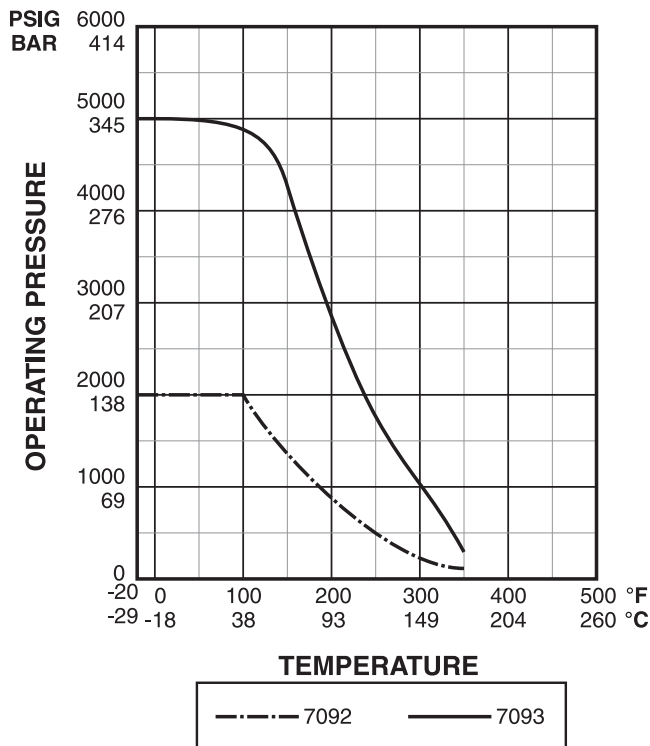

Flow Diagrams 2-way valve

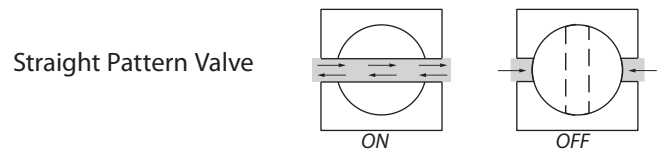

Ultramite™ 70 Series

Materials of Construction

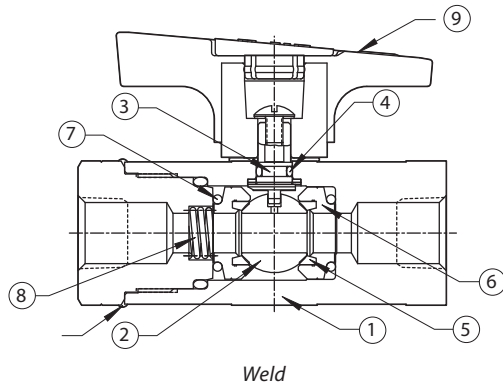

| DESCRIPTION | BRASS | 316 STAINLESS STEEL | MONEL® |
|--|---------------------|---------------------|----------|
| 1 Body | Brass | 316 stainless steel | Monel® |
| 2 Ball | 316 stainless steel | 316 stainless steel | Monel® |
| 3 Stem | 316 stainless steel | 316 stainless steel | Monel® |
| 4 Stem packing† | Viton® | Viton® | Viton® |
| 5 Seats | TFE | TFE | TFE |
| 6 Seat retainers | 316 stainless steel | 316 stainless steel | Monel® |
| 7 Seat washers† 7092 Series 7093 Series* | TFE — | TFE Viton® | TFE — |
| 8 Spring | 316 stainless steel | 316 stainless steel | Monel® |
| 9 Handle | Nylon | Nylon | Nylon |

† Other elastomers are available upon request. Contact your local distributor

* 7093 series only available in 316 stainless steel

Dimensions

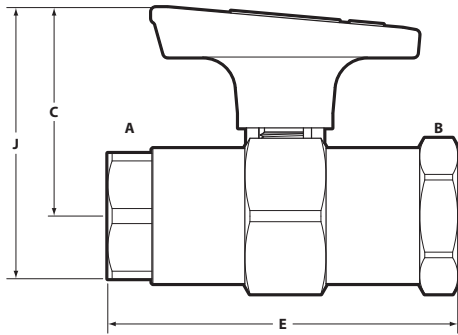

| INLET A | OUTLET B | | C | E | J |
|-----------------|-----------------|------|-------|-------|--------|
| 3/8" female NPT | 3/8" female NPT | inch | 1 7/8 | 3 1/2 | 2 9/16 |
| | | mm | 48 | 89 | 65 |
| 1/2" female NPT | 1/2" female NPT | inch | 1 7/8 | 3 1/2 | 2 9/16 |
| | | mm | 48 | 89 | 65 |
| 1/2" Gyrolok® | 1/2" Gyrolok® | inch | 1 7/8 | 4 7/8 | 2 9/16 |
| | | mm | 48 | 124 | 65 |

Dimensions for reference only, subject to change.

Ordering Options



Optional metal lever handle

Metal Lever Handle

A metal lever handle is available for 7092 and 7093 Series valves. To order, specify 90043-1 with plug button 5982.

Panel Mounting

Panel mounting is available for 7092 and 7093 valves by specifying kit 7200K1.

How to Order Standard Valves



7093F8Y

Ultramite™ 7092 Series Pressure to 2000 psig (138 bar), TFE Seats—TFE Washers

| END CONNECTIONS | | ORDER BY PART NUMBER | | | | |
|-----------------|-----------------|----------------------|---------------|---------|---------|-----|
| INLET | OUTLET | BRASS | 316 ST. STEEL | MONEL® | ORIFICE | Cv |
| 3/8" female NPT | 3/8" female NPT | — | 7092F6Y | 7092F6M | 0.375 | 3.4 |
| 1/2" female NPT | 1/2" female NPT | 7092F8B | 7092F8Y | 7092F8M | 0.375 | 3.4 |
| 1/2" Gyrolok® | 1/2" Gyrolok® | 7092G8B | 7092G8Y | 7092G8M | 0.375 | 3.4 |

Ultramite™ 7093 Series Pressure to 5000 psig (345 bar), TFE Seats—Viton® Washers

| END CONNECTIONS | | ORDER BY PART NUMBER | | | | |
|-----------------|-----------------|----------------------|---------------|---------|---------|-----|
| INLET | OUTLET | BRASS | 316 ST. STEEL | MONEL® | ORIFICE | Cv |
| 3/8" female NPT | 3/8" female NPT | — | 7093F6Y | 7093F6M | 0.375 | 3.4 |
| 1/2" female NPT | 1/2" female NPT | — | 7093F8Y | 7093F8M | 0.375 | 3.4 |
| 1/2" Gyrolok® | 1/2" Gyrolok® | — | 7093G8Y | 7093G8M | 0.375 | 3.4 |

Ultramite™ 70 Series

Ultramite™ 7065 Series (3-way Valve)



Cv Factors: 0.15 to 0.57

The Ultramite™ 7065 3-way ball valve uses 180° handle rotation for diverting flow from one line to another. The oval handle points to the port in use. When the handle is perpendicular to the valve body it is in the shutoff position.

Typical Applications

- Analyzer labs
- Sampling systems
- Fluid diverting/switching

Technical Data

| | |
|------------------------------------|---|
| BODY MATERIAL | 316 stainless steel, brass, Monel® |
| OPERATING PRESSURE RANGE | Moderate vacuum* to 500 psig @ 70° F (34.5 bar @ 21° C) |
| OPERATING TEMPERATURE RANGE | 0° F to +350° F (-18° C to +177° C) |
| ORIFICE SIZE | 0.187" (4.8mm) |
| Cv FACTORS | 0.15 to 0.57 |
| END CONNECTIONS | 1/8" to 3/8" Gyrolok® 1/4" NPT |

* Moderate vacuum is 10⁻³ to 20 torr.

Features & Benefits

- Welded ends secure the end fittings preventing accidental disassembly, enhancing safety.
- Oval trip-proof handle helps prevent accidental actuation for safer operation. The handle also serves as a visual indicator of the port in use, or closed position for increased safety.
- Dyna-Pak® packing provides a leak-tight seal with low operating torque in vacuum or high pressure applications, helping to prevent fugitive emissions.

Pressure vs. Temperature Curve

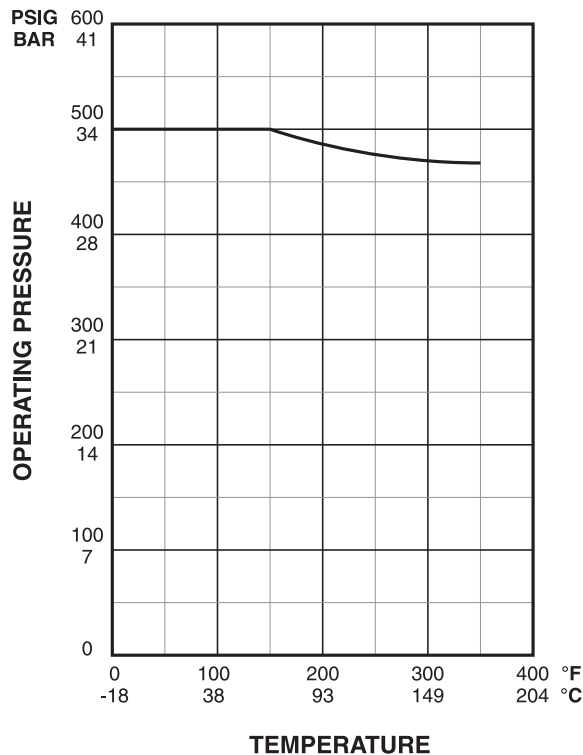

Flow Diagrams 3-way valve

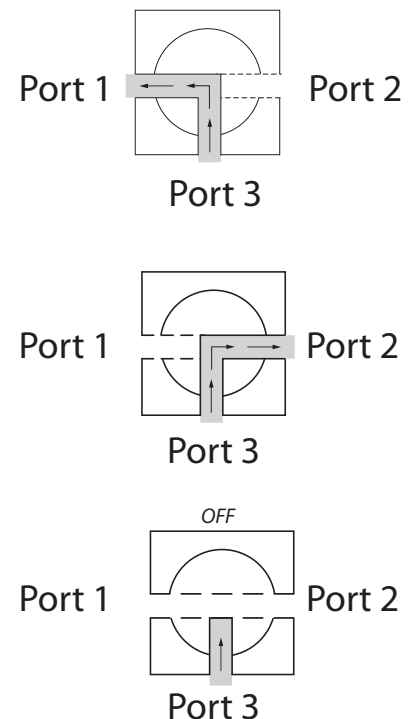

Ultramite™ 70 Series

Materials of Construction

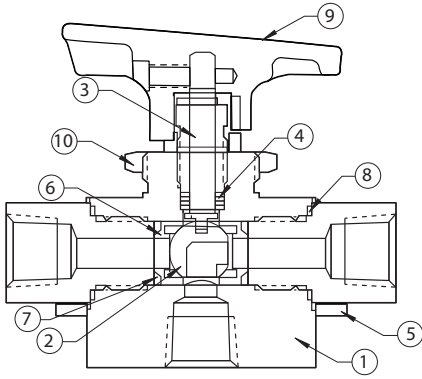

| DESCRIPTION | BRASS | 316 STAINLESS STEEL | MONEL® |
|------------------------|--------------------------------|--------------------------------|---------------------|
| 1 Body | Brass | 316 stainless steel | Monel® |
| 2 Ball | 316 stainless steel | 316 stainless steel | Monel® |
| 3 Stem | 316 stainless steel | 316 stainless steel | Monel® |
| 4 Stem packing | TFE/316 stainless steel wafers | TFE/316 stainless steel wafers | TFE/Monel® wafers |
| 5 Seats | TFE | TFE | TFE |
| 6 Seat retainers | Brass | 316 stainless steel | Monel® |
| 7 Seat washers | TFE | TFE | TFE |
| 8 End fittings gaskets | TFE | TFE | TFE |
| 9 Handle | Nylon | Nylon | Nylon |
| 10 Panel mounting nut | Nickel-plated brass | 316 Stainless Steel | Nickel-plated brass |

Dimensions

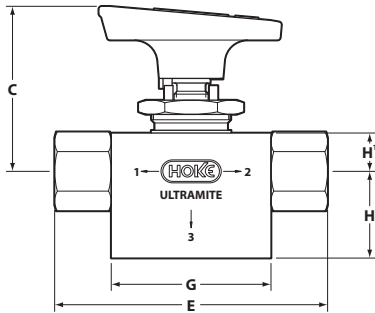

| END CONNECTIONS | | C | E | G | H | H' |
|-----------------|------|---------------------------------|--------------------------------|-------------------------------|--------------------------------|--------------------------------|
| 1/8" Gyrolok® | inch | 1 ¹⁵ / ₁₆ | 3 ⁷ / ₁₆ | 1 ³ / ₄ | 2 | 7 ¹ / ₁₆ |
| | mm | 49 | 87 | 44 | 51 | 11 |
| 1/4" Gyrolok® | inch | 1 ¹⁵ / ₁₆ | 3 ³ / ₈ | 1 ³ / ₄ | 2 ¹ / ₁₆ | 7 ¹ / ₁₆ |
| | mm | 49 | 92 | 44 | 52 | 11 |
| 1/4" female NPT | inch | 1 ³ / ₄ | 3 | 1 ³ / ₄ | 1 ⁵ / ₁₆ | 7 ¹ / ₁₆ |
| | mm | 44 | 76 | 44 | 24 | 11 |
| 3/8" Gyrolok® | inch | 1 ¹⁵ / ₁₆ | 3 ⁷ / ₈ | 1 ³ / ₄ | 2 ³ / ₁₆ | 7 ¹ / ₁₆ |
| | mm | 49 | 98 | 44 | 56 | 11 |

Panel Mounting

Panel hole: 5⁷/₆₄" (23mm) diameter

Panel thickness: 3³/₁₆" (5mm) diameter

Dimensions for reference only, subject to change.

How to Order



7065F4Y

Ultramite™ 7065 Series Pressure to 500 psig (35 bar)

| END CONNECTIONS | | ORDER BY PART NUMBER | | | | |
|-----------------|-----------------|----------------------|---------------|---------|---------|------|
| INLET | OUTLET | BRASS | 316 ST. STEEL | MONEL® | ORIFICE | Cv |
| 1/8" Gyrolok® | 1/8" Gyrolok® | 7065G2B | 7065G2Y | — | 0.093 | 0.15 |
| 1/4" Gyrolok® | 1/4" Gyrolok® | 7065G4B | 7065G4Y | 7065G4M | 0.187 | 0.57 |
| 1/4" female NPT | 1/4" female NPT | 7065F4B | 7065F4Y | 7065F4M | 0.187 | 0.57 |
| 3/8" Gyrolok® | 3/8" Gyrolok® | 7065G6B | 7065G6Y | 7065G6M | 0.187 | 0.57 |

Ultramite™ 70 Series Ball Valve Options

Handle Locking Kit

Safety lockout kits are available for applications which must conform to Code of Federal Regulations 29CFR Part 1910, OSHA

Safety and Health Act, and other international regulations. Valves can be locked in either an opened or closed position with the stainless steel upper and lower locking plates. Lock with readily available padlocks or commercially available multiple lockout devices. Locking kits include the locking plates and assembly instructions. To order a safety lockout kit for Ultramite™ 7015 and 7022 Series valves, specify kit 7100K18; for Ultramite™ 7092 and 7093 Series valves, specify kit 7200K7; for 7065 Series valve, specify kit 7600K1.

Cleaning and Testing

When ordering, please specify if oxygen cleaning or helium leak testing is required.

Additional Sizes

Additional sizes and options are available on special request. Please consult your local HOKE distributor.

For Your Safety

It is solely the responsibility of the system designer and user to select products suitable for their specific application requirements and to ensure proper installation, operation, and maintenance of these products. Material compatibility, product ratings and application details should be considered in the selection. Improper selection or use of products described herein can cause personal injury or property damage.

VCR® is a registered trademark of Cajon Co.

Dow Corning® is a registered trademark of Dow Corning Corporation

Nylatron® is a registered trademark of DSM Engineering Plastic Products

Teflon® is a registered trademark of the DuPont Company

Kalrez® and Viton® are registered trademarks of DuPont DOW Elastomers

Dyneon™ is a trademark of Dyneon

Elgiloy® is a registered trademark of Elgiloy Specialty Metals

Gyrolok®, Dyna-Pak®, Rotoball®, Flomite®, Selectomite®, and Multimite® are registered trademarks of HOKE, Inc.

Space Savers™, Ultramite™, and Vaculok™ are trademarks of HOKE, Inc.

Rulon® is a registered trademark of Saint-Gobain Corporation

Monel® and Inconel® are registered trademarks of Special Metals Corporation

Grafoil® is a registered trademark of Graf Tech International Ltd.

PEEK™ is a trademark of Victrex PLC

www.dowcorning.com

www.dsm.com

www.dupont-dow.com

www.3m.com

www.elgiloy.com

www.hoke.com

www.hoke.com

www.saint-gobain.com

www.specialmetals.com

www.graftech.com

www.victrex.com